

Installation instructions

For set # 8.3131

2013 Scion FR-S

Front Control Arm Bushings



1131 VIA CALLEJON, SAN CLEMENTE, CA 92673

© 2013 Energy Suspension. All rights reserved.
 May not be reproduced, in any form, or by any means,
 without the written consent of Energy Suspension.

It is recommended that if you are unfamiliar with this type of work that you refer to a qualified service center specializing in this type of work. It is also recommended that if you choose to do this work yourself that a factory service manual be obtained for the proper procedures pertaining to removal, replacement and proper torque specifications for your vehicle. This instruction set is intended as a guideline for the safe installation of Energy Suspension's polyurethane bushings, once you have removed the factory components from your vehicle. Wheel alignment is almost always disturbed when suspension components are removed or replaced. It is recommended that you have the alignment checked on your vehicle at a qualified alignment shop. Energy Suspension recommends that you read over all the installation instructions and check all P/N's and quantities in the parts list before you start. Call customer service at 949-361-3935 if the parts in your kit do not match this parts list. Prior to installation, make sure that your vehicle is in excellent mechanical condition and that there are no suspension or steering related problems. This part has been designed to work only with a vehicle that is in good state of repair. No matter how carefully we design our parts, this is one area we have no control over and cannot be held responsible.

Parts list:

- 2 - 3528 Front Position Vertical Bushing
- 2 - 15.10.676.39 Front Position Inner Sleeve
- 2 - 15.02.51.39 Front Position Outer Shell
- 4 - 2914 Rear Position Horizontal Bushing
- 2 - 15.10.360.39 Rear Position Inner Sleeve
- 1 - 17606 Instruction Sheet

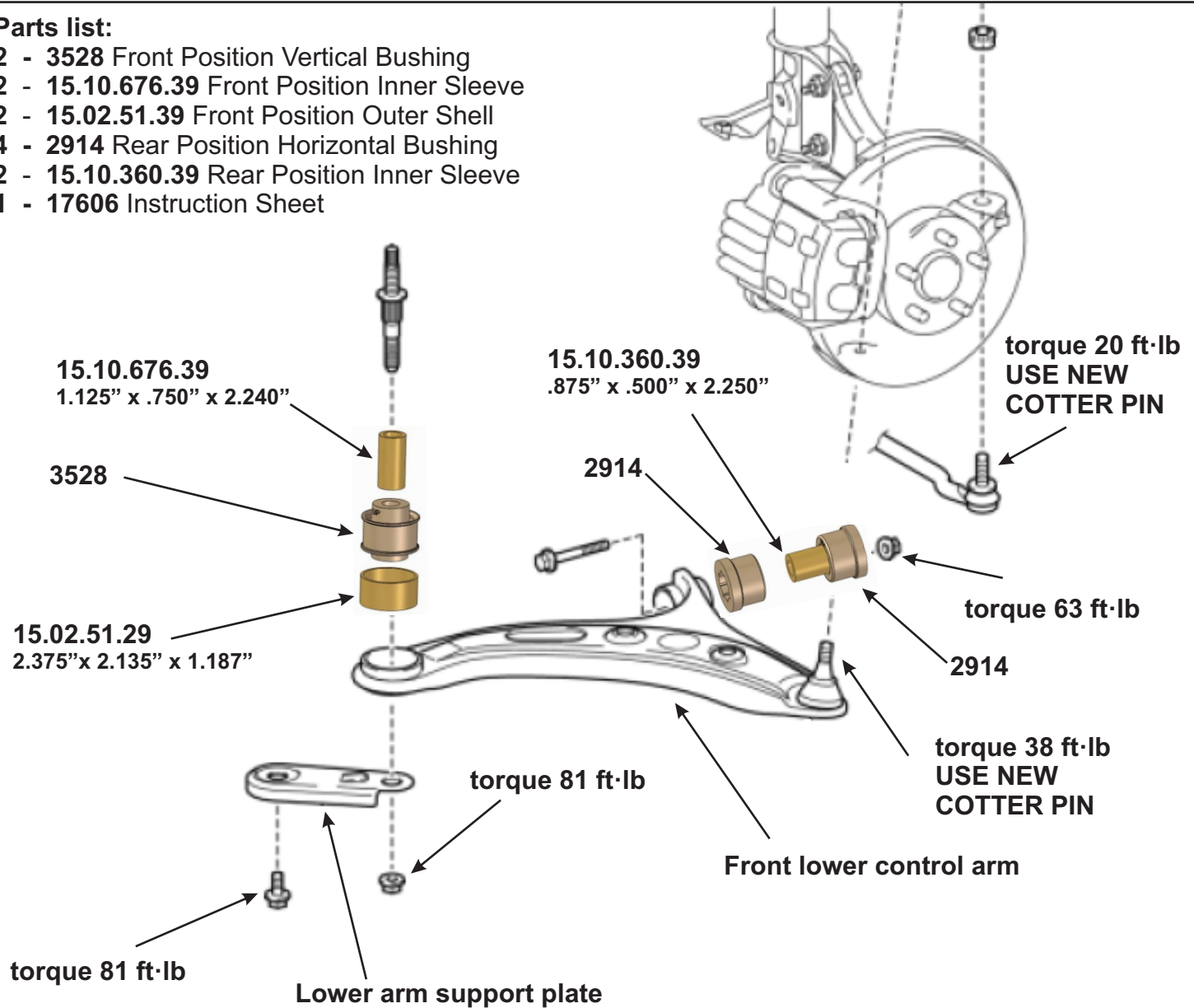

Installation instructions

For set # 8.3131

2013 Scion FR-S

Front Control Arm Bushings

© 2013 Energy Suspension. All rights reserved.
May not be reproduced, in any form, or by any means,
without the written consent of Energy Suspension.

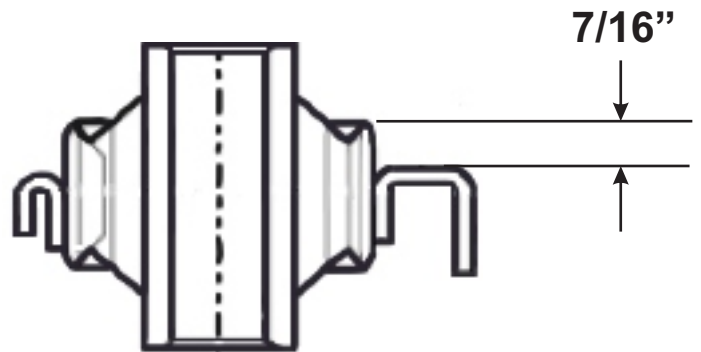
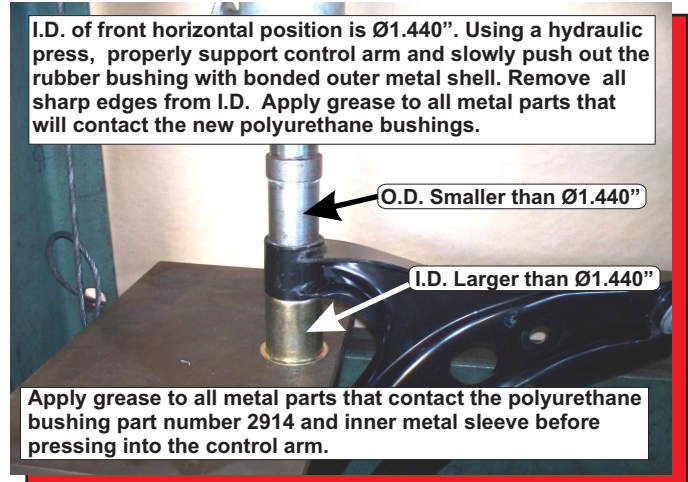
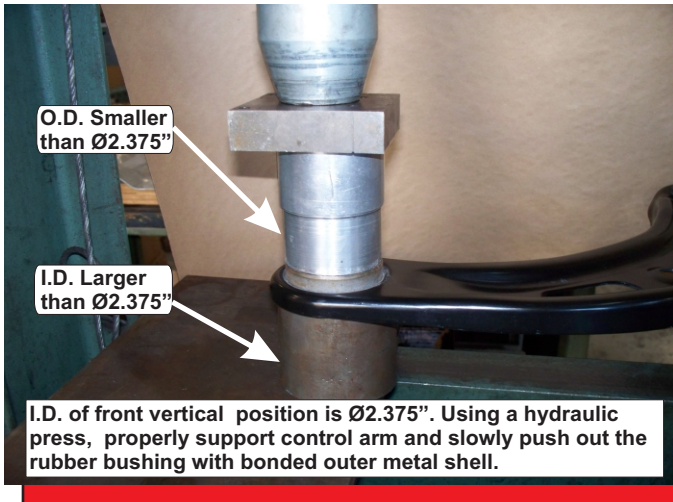

Press the new shell into the control arm until there is $7/16''$ sticking out on the upper side of the control arm. Install the bushing with p/n 3528 up. Only grease the leading edge to help get the bushing started. Do not grease the I.D. when installing the inner sleeve.